

CONFIGURATION

Overhead Guard	Oil Pressure Warning
Top Rain Shelter	Electric Horn
Pedal Rubber	Reversing Buzzer
Semi-suspension Seat	Key Shutoff Device
Automatic Shift	Adjustable Steering Column
Electro-hydraulic Reversing	Lifting and Tilting Joysticks
Free Mast (2 Stage)	Two Piece Multiplex Valve
Standard Forks	Full-hydraulic Power Steering
Combination Instrument	Tilting Cylinder Latching Valve
Working Hour Meter	Transmission Oil Filter
Oil Content Meter	Torque Converter Oil Gauge
Water-thermometer	Traction Pin
Charging Indicator	Tool Box
Power Master Switch	Torque Converter Oil Temperature Alarm
Full Set LED Lamps	Rear Working Lamp
Working Warning Light	

OPTIONAL

Suspension Seat	Sound-light Alarm
Front Windscreen	Fire Extinguishing Muffler
High Level Exhaust	Lengthen Fork Jacket
Double Air Filter	Tilting Cylinder Sleeve
Oil Bath Air Filter	Steering Cylinder Sleeve
Reversing Voice Horn	Custom Colors
Overspeed Alarm, 10km/h	Multiple Work Attachments
Electric Fan	

PRODUCT FEATURES

Good Heat Dissipation
Special design to increase radiator ability, superior performance. Ensure efficient operation in ventilation of container or ship.

Mobility & Flexible
Low vehicle height, suitable for container operation. Narrow body enhances mobility of container operation.

Operating Comfort
Adopted interactive ergonomic design to improve operating comfort.

Intelligent Reversing
Electro-hydraulic Reversing System. Easy to operate and labor-saving.

Safe and Reliable
Full-hydraulic power brake. small brake control force.

High Stability
Steering axle has buffering device. Damping performance is superior.

The following blank can be used for notes or comments.

**For more information on Lonking products,
Please contact our local agent:**

Lonking, Lonking LG Series and their respective logos, as well as corporate identity in this leaflet are trademarks of Lonking Holdings Ltd., and may not be used without written permission.
2020/04

Specifications and design are subject to change without prior notice.
Machines shown may not include optional accessories.

LONGKING 龙工

LG60/80/100DTBIII

BALANCEWEIGHT TYPE FORKLIFT TRUCK WITH ENGINE

Efficiency Rules the Future



LONGKING (FU JIAN) INTERNATIONAL TRADE CO., LTD.

LONGKING HOLDINGS LIMITED

Add: 26 Minyi Road, Xinqiao, Songjiang Industrial Zone, Shanghai

Tel: +86-21-3760 2242 E-mail: export@lonking.cn

<http://www.lonkinggroup.com>

	LG60DTB III	LG80DTB III	LG100DTB III
Rated Capacity (kg)	6000	8000	10000
Load Center (mm)	600	600	600
Power Type	Diesel	Diesel	Diesel

OVERALL SPECIFICATIONS

Type	No.	Item	Code	Unit	Data		
Identification	1.01	Manufacturer			LONKING		
	1.02	Model			LG60DTB III	LG80DTB III	LG100DTB III
	1.03	Power type			Diesel		
	1.04	Rated capacity	Q	kg	6000	8000	10000
	1.05	Load center	J	mm	600		
Dimensions	2.01	STD Max height (with backrest)		mm	3932	3932	3262
	2.02	STD Max lifting height	h1	mm	2500 (Free)	2500 (Free)	2100 (Free)
	2.03	Overhead guard height	h4	mm	2180		
	2.04	Overall length (with fork)	L1	mm	4780	4995	5540
	2.05	Wheelbase	L2	mm	2250	2250	2800
	2.06	Front overhang	L3	mm	617	647	700
	2.07	Rear overhang	L4	mm	715	900	840
	2.08	Min. ground clearance (Frame/Mast)	m1/m2	mm	300/150	300/150	380/245
	2.09	Overall width	W1	mm	1945		
	2.10	Adjusting range of fork (outside)		mm	300-1805	300-1805	450-1780
	2.11	STD Fork size (L5*W*T)		mm	1220×150×60	1220×150×80	1220×170×70
	2.12	Front wheel tread	S	mm	1440	1440	1430
	2.13	Rear wheel tread	P	mm	1500		
	2.14	Min. turning radius	R1	mm	3280	3500	4000
	2.15	Min aisle width for pallet 1000×1200, crossways		mm	5315	5445	6400
	2.16	Min aisle width for pallet 800×1200, lengthways		mm	5315	5445	6400
Tires	3.01	Wheels number, front/rear (X=driven wheels)			X=4/2		
	3.02	Tires type			Solid/Pneumatic		Pneumatic
	3.03	Tires size, front			250-15	250-15	8.25-20-14PR
	3.04	Tires size, rear			250-15-16PR	250-15-16PR	9.00-16-16PR
Other Details	4.01	Max. traveling speed, loaded/unloaded		km/h	23/25	23/25	24/28
	4.02	Max. lifting speed, loaded/unloaded		mm/s	510/530	480/510	330/370
	4.03	Lowering speed, loaded/unloaded		mm/s	350/300	350/300	350/300
	4.04	Max. traction, loaded		KN	64	64	62
	4.05	Max. gradient, loaded/unloaded		%	35/20	25/20	22/20
	4.06	STD operating weight (with oil & water)		kg	8750	10200	11900
	4.07	Axles loading, front/rear (loaded)		kg	13100/1650	16400/1800	19600/2300
	4.08	Axles loading, front/rear (unloaded)		kg	3900/4850	4000/6200	4800/7100
	4.09	Service brake			Power brake-pedal		
	4.10	Parking brake			Mechanical-hand brake lever		
	4.11	Drive type			Automatic		
	4.12	Number of gear (front/rear)			2/2		
	4.13	Fuel tank capacity		L	140		
	4.14	Battery votage/capacity		V/Ah	2×12/90		

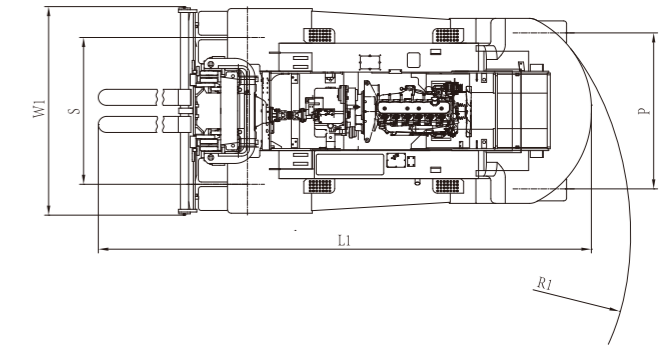
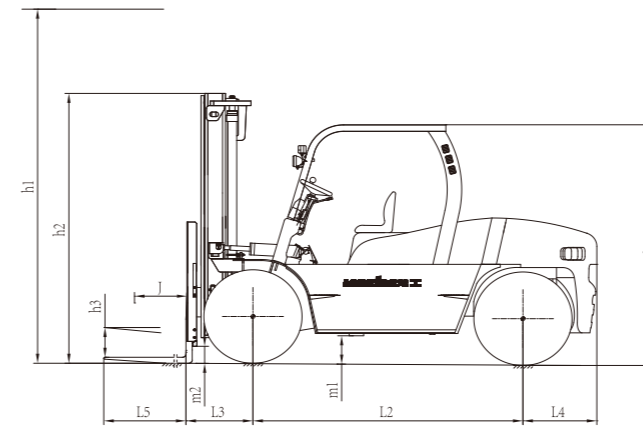

MAST SPECIFICATIONS

2 Stage Standard Mast

Mast Model	h1 Max Lifting Height (mm)	Load Capacity (J=600mm) (kg)			h2 Lowered Mast Height (mm)			h3 Free Lifting Height, without backrest (mm)			Mast tilt α/β (°)
		LG60DTB III	LG80DTB III	LG100DTB III	LG60DTB III	LG80DTB III	LG100DTB III	LG60DTB III	LG80DTB III	LG100DTB III	
M200	2000	6000	8000	\	1950	1950	\	206	226	\	10/12
M240	2400	6000	8000	\	2150	2150	\	206	226	\	10/12

2 Stage Free Mast-Super Free Lifting Height

Mast Model	h1 Max Lifting Height (mm)	Load Capacity (J=600mm) (kg)			h2 Lowered Mast Height (mm)			h3 Free Lifting Height, without backrest (mm)			Mast tilt α/β (°)
		LG60DTB III	LG80DTB III	LG100DTB III	LG60DTB III	LG80DTB III	LG100DTB III	LG60DTB III	LG80DTB III	LG100DTB III	
ZM210	2100	\	\	10000	\	\	2170	\	\	1050	10/12
ZM250	2500	6000	8000	\	2160	2160	\	1140	1160	\	10/12

Note: With backrest, free lifting height reduces 360mm.

LG60/80DTB III



LG100DTB III



ENGINE OPTIONAL

Engine Model	Emission	Manufacturer	Rated Power	Max. Torque (N.m/rpm)	Bore/Cylinders Number/Displacement	Fuel Consumption
CA4DF3-12GCG3U-LG10	CHN III	XCHAI	85kW/2200rpm	460/1300-1700	110/4/4.75	220g/kW.h
QSB4.5	Euro IIIIA	DF CUMMINS	82kW/2200rpm	488/1500	107/4/4.5	230g/kW.h
A-6BG1QC-02	Euro I	ISUZU	82.4kW/2000rpm	416/1500	105/6/6.494	232g/kW.h