

CONFIGURATION

Overhead Guard	Combination Instrument
Top Rain Shelter	Working Hour Meter
Pedal Rubber	Oil Content Meter
Semi-suspension Seat	Water-thermometer
Automatic Shift	Charging Indicator
Electro-hydraulic Reversing	Neutral Position Switch
Wide Field Mast (2 Stage)	Oil Pressure Warning
Backrest	Electric Horn
Standard Forks	LED Signal Lamp
Adjustable Steering Column	Reversing Buzzer
Lifting and Tilting Joysticks	Key Shutoff Device
Two Piece Multiplex Valve	Push-button Parking brake
Full-hydraulic Power Steering	Torque Converter Oil Gauge
Tilting Cylinder Latching Valve	Traction Pin
Transmission Oil Filter	Tool Box
Power Master Switch	

OPTIONAL

Solid Tires	Driving OPS
Cabin	Full Set OPS (Including drive and lift)
Working Warning Light	Torque Converter Oil Temperature Alarm
Suspension Seat	Full Set LED Lamps
Warm-air Blower	Reversing Voice Horn
Front Windscreen	Overspeed Alarm, 10km/h
Rear Working Lamp	Electric Fan
High Level Exhaust	Sound-light Alarm
Double Air Filter	Lengthen Fork Jacket
Oil Bath Air Filter	Tilting Cylinder Sleeve
Fire Extinguishing Muffler	Steering Cylinder Sleeve
Widen Fork Frame	Custom Colors
Multiple Work Attachments	

PRODUCT FEATURES

<p>Good Heat Dissipation Cooling system is reasonable optimized, which improves cooling performance significantly. Thus improving reliability and durability of key components such as gearbox and engine.</p>
<p>Lowering Energy Consumption Optimized design of load sensing hydraulic system reduces vehicle fuel consumption effectively.</p>
<p>Operating Comfort Adopted interactive ergonomic design to improve operating comfort. Equipped with wide field of view mast to improve driver's field of view.</p>
<p>Intelligent Reversing Electro-hydraulic Reversing System. Easy to operate and labor-saving. Upgrade new intelligent shift system, prevent the second gear starting, ensure reliability of gearbox.</p>
<p>Convenient Maintenance Interior space of car body is more spacious. Parts Positions are more reasonable. Opening angle of hood is increased to 80°. Maintainability of machine is better.</p>
<p>High Reliability Strength of the core structural parts of car body, mast and hood has been enhanced greatly to make whole vehicle more solid.</p>

The following blank can be used for notes or comments.

**For more information on Lonking products,
Please contact our local agent:**

Lonking, Lonking LG Series and their respective logos, as well as corporate identity in this leaflet are trademarks of Lonking Holdings Ltd., and may not be used without written permission.
2020/06

Specifications and design are subject to change without prior notice.
Machines shown may not include optional accessories.

LONGKING 龙工

LG85/100DTIII

BALANCEWEIGHT TYPE FORKLIFT TRUCK WITH ENGINE

Efficiency Rules the Future



LONGKING (FU JIAN) INTERNATIONAL TRADE CO., LTD.

LONGKING HOLDINGS LIMITED

Add: 26 Minyi Road, Xinqiao, Songjiang Industrial Zone, Shanghai

Tel: +86-21-3760 2242 E-mail: export@lonking.cn

<http://www.lonkinggroup.com>

	LG85DTIII	LG100DTIII
Rated Capacity (kg)	8500	10000
Load Center (mm)	600	600
Power Type	Diesel	Diesel

- Rated Capacity (kg)
- Load Center (mm)
- Power Type

OVERALL SPECIFICATIONS

Type	No.	Item	Code	Unit	Data	
Identification	1.01	Manufacturer			LONKING	
	1.02	Model			LG85DT III	LG100DT III
	1.03	Power type			Diesel	
	1.04	Rated capacity	Q	kg	8500	10000
	1.05	Load center	J	mm	600	
Dimensions	2.01	STD Max height (with backrest)		mm	4345	4500
	2.02	STD Max lifting height	h1	mm	3000	3000
	2.03	Overhead guard height	h4	mm	2560	2560
	2.04	Overall length (with fork)	L1	mm	5465	5780
	2.05	Wheelbase	L2	mm	2500	2800
	2.06	Front overhang	L3	mm	705	720
	2.07	Rear overhang	L4	mm	740	740
	2.08	Min.ground clearance (Frame/Mast)	m1/m2	mm	300/245	300/245
	2.09	Overall width	W1	mm	2165	2165
	2.10	Adjusting range of fork (outside)		mm	450-2090	450-2090
	2.11	STD Fork size (L5*W*T)		mm	1520×170×70	1520×175×85
	2.12	Front wheel tread	S	mm	1600	1600
	2.13	Rear wheel tread	P	mm	1700	1700
	2.14	Min.turning radius	R1	mm	3650	3900
	2.15	Min aisle width for pallet 1000×1200,crossways		mm	5755	6020
	2.16	Min aisle width for pallet 800×1200,lengthways		mm	5755	6020
Tires	3.01	Wheels number, front/rear (X=driven wheels)			X=4/2	
	3.02	Tires type			Pneumatic	
	3.03	Tires size, front			9.00-20-14PR	
	3.04	Tires size, rear			9.00-20-14PR	
Other Details	4.01	Max.traveling speed, loaded/unloaded		km/h	24/28	24/28
	4.02	Max.lifting speed, loaded/unloaded		mm/s	390/420	330/350
	4.03	Lowering speed, loaded/unloaded		mm/s	420/410	310/300
	4.04	Max.traction, loaded		KN	60	60
	4.05	Max.gradient, loaded/unloaded		%	23/20	21/20
	4.06	STD operating weight (with oil & water)		kg	12250	13400
	4.07	Axles loading,front/rear (loaded)		kg	18550/2200	21100/2300
	4.08	Axles loading,front/rear (unloaded)		kg	5450/6800	6100/7300
	4.09	Service brake			Power brake-pedal	
	4.10	Parking brake			Mechanical-hand brake lever	
	4.11	Drive type			Automatic	
	4.12	Number of gear (front/rear)			2/2	
	4.13	Fuel tank capacity		L	160	
	4.14	Battery votage/capacity		V/Ah	2×12/90	

ENGINE OPTIONAL

Engine Model	Emission	Manufacturer	Rated Power	Max.Torque (N.m/rpm)	Bore/Cylinders Number/Displacement	Fuel Consumption
CA6110/125G5-LG20	CHN II	XICHA	83kW/2000rpm	450/1400-1500	110/6/7.127L	230g/kW.h
CA4DF3-12GCG3U-LG10	CHN III	XICHA	85kW/2200rpm	460/1300-1700	110/4/4.75L	220g/kW.h
YC4A125-T300	CHN III	YUCHAI	92kW/2200rpm	480/1400-1800	108/4/4.837L	230g/kW.h
A-6BG1QC-02	Euro I	ISUZU	82.4kW/2000rpm	416/1500	105/6/6.494L	232g/kW.h
QSB4.5-C110-30	Euro IIIA	DF CUMMINS	82kW/2200rpm	488/1500	107/4/4.5L	230g/kW.h

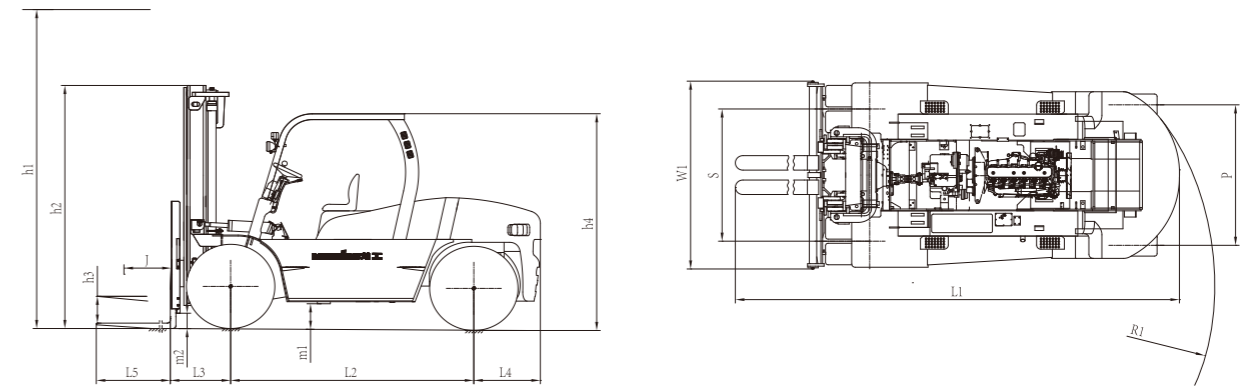

MAST SPECIFICATIONS

2 Stage Standard Mast-Super Wide Field

Mast Model	h1 Max Lifting Height(mm)	Load Capacity (J=600mm) (kg)		h2 Lowered Mast Height (mm)		h3 Free Lifting Height, without backrest (mm)		Mast tilt α/β (°)	
		LG85DTIII	LG100DTIII	LG85DTIII	LG100DTIII	LG85DTIII	LG100DTIII	LG85DTIII	LG100DTIII
M230	2300	/	10000	/	2495	200	215	/	10/12
M250	2500	8500	/	2445	/	200	215	10/12	/
M270	2700	8500	10000	2545	2695	200	215	10/12	10/12
M300	3000	8500	10000	2695	2845	200	215	10/12	10/12
M330	3300	8500	10000	2845	2995	200	215	10/12	10/12
M350	3500	8500	10000	2945	3095	200	215	10/12	10/12
M375	3750	8500	10000	3070	3220	200	215	10/12	10/12
M400	4000	8500	10000	3245	3395	200	215	10/12	10/12
M425	4250	8500	10000	3370	3520	200	215	6/6	6/6
M450	4500	8500	10000	3495	3645	200	215	6/6	6/6
M475	4750	8200	10000	3620	3770	200	215	6/6	6/6
M500	5000	8200	10000	3745	3895	200	215	6/6	6/6
M550	5500	7850	9000	4045	4195	200	215	6/6	6/6
M600	6000	7400	8000	4295	4445	200	215	6/6	6/6

2 Stage Free Mast-Super Free Lifting Height

Mast Model	h1 Max Lifting Height(mm)	Load Capacity (J=600mm) (kg)		h2 Lowered Mast Height (mm)		h3 Free Lifting Height, without backrest (mm)		Mast tilt α/β (°)	
		LG85DTIII	LG100DTIII	LG85DTIII	LG100DTIII	LG85DTIII	LG100DTIII	LG85DTIII	LG100DTIII
ZM200	2000	8500	10000	2345		867	882	10/12	10/12
ZM225	2250	8500	10000	2470		992	1007	10/12	10/12
ZM250	2500	8500	10000	2595		1117	1132	10/12	10/12
ZM270	2700	8500	10000	2695		1217	1232	10/12	10/12
ZM300	3000	8500	10000	2845		1367	1382	10/12	10/12
ZM330	3300	8500	10000	2995		1517	1532	10/12	10/12
ZM350	3500	8500	10000	3095		1617	1632	10/12	10/12
ZM370	3700	8500	10000	3195		1717	1732	10/12	10/12
ZM400	4000	8500	10000	3395		1917	1932	10/12	10/12
ZM425	4250	8500	10000	3520		2042	2057	6/6	6/6
ZM450	4500	8500	10000	3645		2167	2182	6/6	6/6

3 Stage Free Mast-Super Free Lifting Height

Mast Model	h1 Max Lifting Height(mm)	Load Capacity (J=600mm) (kg)		h2 Lowered Mast Height (mm)		h3 Free Lifting Height, without backrest (mm)		Mast tilt α/β (°)	
		LG85DTIII	LG100DTIII	LG85DTIII	LG100DTIII	LG85DTIII	LG100DTIII	LG85DTIII	LG100DTIII
ZSM360	3600	7500	8000	2545		1180	1195	10/12	10/12
ZSM400	4000	7500	8000	2675		1310	1325	10/12	10/12
ZSM435	4350	7500	8000	2795		1430	1445	6/6	6/6
ZSM450	4500	7500	8000	2845		1480	1495	6/6	6/6
ZSM480	4800	7500	7500	2945		1580	1595	6/6	6/6
ZSM500	5000	7500	7500	3010		1645	1660	6/6	6/6
ZSM540	5400	7000	7000	3200		1835	1850	6/6	6/6
ZSM600	6000	6000	6400	3400		2035	2050	6/6	6/6
ZSM630	6300	5800	5800	3500		2135	2150	6/6	6/6
ZSM650	6500	5500	5800	3565		2200	2215	6/6	6/6